

Product Information

Mixing and Dispensing Machine

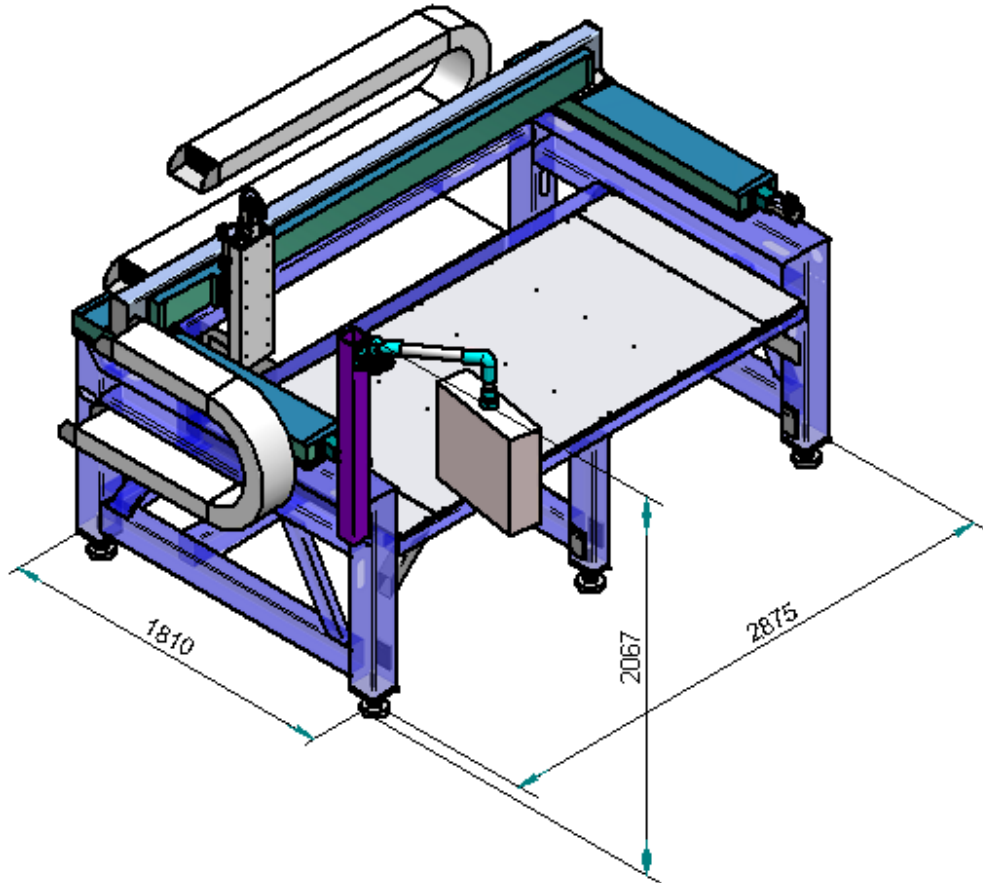
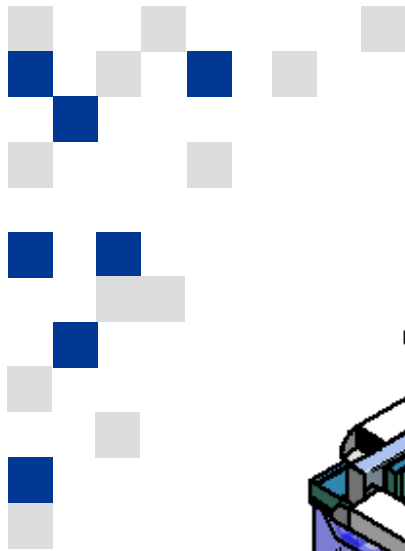

B5800

Fully Automatic Mixing and Dispensing Machine for Large Parts

The B5800 is a portal machine to support the dispensing of reactive resins on large parts. The 3-axis system allows the B5800 to have superior flexibility in meeting unique application requirements. This machine distinguishes itself through an integrated dispensing and motion controller concept and modular integration of automation processes.

- ✓ Supports either Static or Dynamic mixing technology
- ✓ Variable selection of mix ratio and dispensing flow rates
- ✓ Can be integrated with an in-line conveyor or as a lean cell
- ✓ Multiple dispense heads can be installed to reduce cycle times

Manual workplace

**Production cell
(For integration)**

Production line

Process & Services

Dispensing Technology

Automation Technology

Impregnation Technology

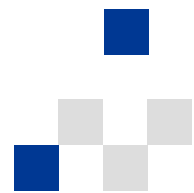

Product information

Dispensing Machine B5800

Key Components

✓ Dispensing systems

- Dynamic mixing system
- Static mixing system
- Single part system
- Multiple mix and dispense heads

✓ Coordination systems

- 4-axis system with servo-drive X-Y Y-Z
- 3D-interpolated motion

✓ Controller

- Beckhoff
- Process visualisation via PC-screen

Modular Options

- Material preparation system MPS
- Supply from pressure tanks or cartridge
- Manual/automatic refill station
- Temperature regulation
- Material recirculation
- Degassing system
- Filling level monitoring, digital
- Needle Cleaning system
- Solvent recirculation unit
- Integrated weighing scale
- Needle check with offset correction
- Process and process data control
- Product and machine data tracking
- Integration Possibilities:
 - Pallet transport conveyor
 - Rotary indexing table
 - Robotic loading and part handling

Technical Data

Size (w x h x d):	Variable upon need
Weight:	Configuration dependent
Working area:	Variable upon need
Axis velocity:	0.5 m / sec.
Electrical power supply:	230V / 3Ø / 32 A / 50/60 Hz
Air pressure supply:	max. 6 bar
Color:	RAL 7035

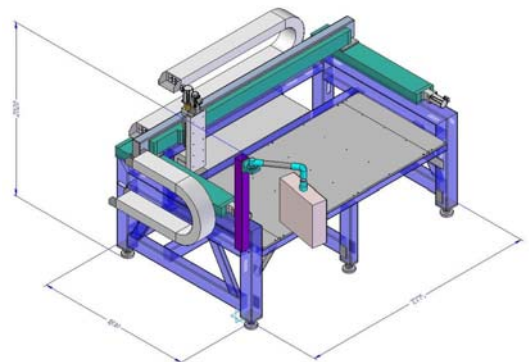

Your Competitive Edge - Our Service

- ✓ Service hotline
- ✓ On-site technical support available
- ✓ Same day spare parts shipment
- ✓ Process and part optimisation testing using our in-house laboratories
- ✓ Training sessions for machine operators, Maintenance, and manufacturing engineers
- ✓ Remote diagnosis via internet

Contact



BARTEC Dispensing Technology, Inc.

5889 S. Garnett Rd.

Tulsa, OK 74146-6848

Phone: +1 918 250-6496

Fax: +1 918 250-6564

Email: sales@bartec-dt.com

www.bartec-dt.com