

Product Information

Mixing and Dispensing Machine

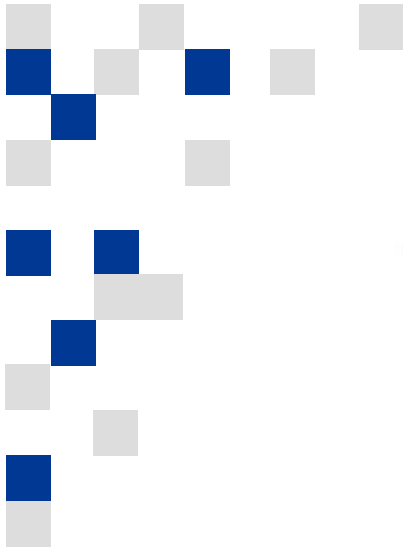

Dispensing Technology

Automation Technology

B5200

Fully automatic mixing and dispensing machine for continuous series production

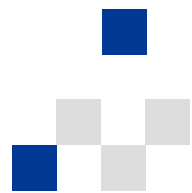

The dispensing cell B5200 design and controls capability is well suited for dispensing processes with a high degree of automation. The integrated PC allows continuous process control and product data tracking during production. State of the art technology from BDT guarantees an optimal interaction between precision, reliability and flexibility.

- ✓ Dynamic mix head capable for fast cure and hard to mix materials
- ✓ Variable selection of mix ratio and flow rates
- ✓ Continuous mixing and dispensing technology
- ✓ Can be integrated with in-line conveyor or as a lean cell

Manual workplace

**Production cell
(for integration)**

Production line

Process & Services

Impregnation Technology

Product information

Mixing and dispensing machine B5200

Key Components

✓ Dispensing systems

- Dynamic mixing system
- Static mixing system
- Multiple head single valve

✓ Coordination systems

- 3-axis system with servo-drive X-Y-Z, ball screw axis
- 3D-interpolated motion

✓ Controller

- Beckhoff
- Process visualization via color PC screen

Modular Options

- Material preparation system MPS
- Supply from pressure tanks or cartridge
- Manual/automatic refill station
- Temperature regulation
- Material recirculation
- Degassing system
- Filling level monitoring, digital
- Cleaning system
- Solvent recirculation unit
- Integrated weight check scale
- Needle check with offset correction
- Process and process data control
- Product and machine data tracking
- Integration of automation processes
- Integration Possibilities:
 - Pallet transport conveyor
 - Rotary indexing table
 - Manual double slide units

Technical Data

Size (w x h x d):	1.190 x 2.200 x 1.600 mm
Weight:	800 kg (without vessels)
Working area:	500 x 700 x 200 mm
Repeatability:	+/- 0.052 mm / axis (300 mm)
Axis velocity:	0.5 m / sec.
Electrical power supply:	240 V / 3Ø / 32 A / 50/60 Hz
Air pressure supply:	max. 6 bar
Color:	RAL 7035

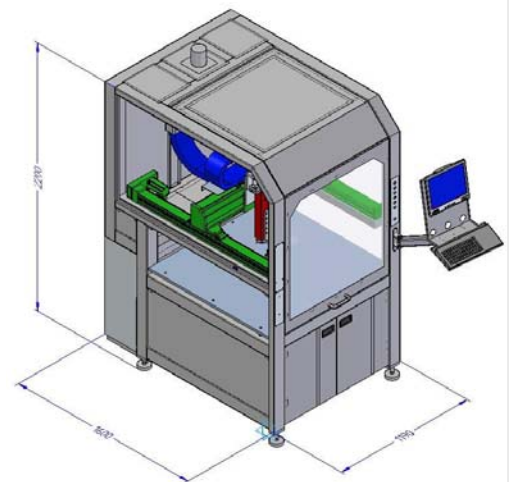

Your Competitive Edge - Our Service

- ✓ Service hotline
- ✓ On-site technical support available
- ✓ Same day spare parts shipment
- ✓ Process and part optimization testing using in-house laboratories
- ✓ Training sessions for machine operators, maintenance and manufacturing engineers
- ✓ Remote diagnosis via internet

Contact



BARTEC Dispensing Technology, Inc.

5889 S. Garnett Rd.

Tulsa, OK 74146-6848

Phone: +1 (918) 250-6496

Fax: +1 (918) 250-6564

Email: sales@bartec-dt.com

www.bartec-dt.com