

Product information

Dispensing machine B-3500



The B-3500 is a semi-automated dispensing machine for a wide range of integration possibilities. It combines the advantages of a mid series and plc-controlled system with different mixing technologies.

A plc controls all process-related parameters that are visualized by a menu-driven interface. The parameters could be adjusted via a regular keyboard.

- Cleartext menu-driven interface; visualization on a 17" screen
- Pneumatically or powered Y- and Z-axis
- Compact dispensing machine with integrated switch cabinet
- Monitoring of potlife, working pressure, filling levels

Application examples of the B-3500

B-3500 with waste bin



B-3500 with solvent recirculation unit



B-3500 with material preparation



B-3500 with housing



Technical data

Size (w x h x d):	1.420 x 1.890 x 500 mm
Weight:	ca. 300 kg (without vessels)
Working area:	Y: 370 mm; Z: 100 mm
Controller:	Beckhoff
Electrical power supply:	440 V / 16 A / 50 Hz
Air pressure supply:	> 6 bar

Layout

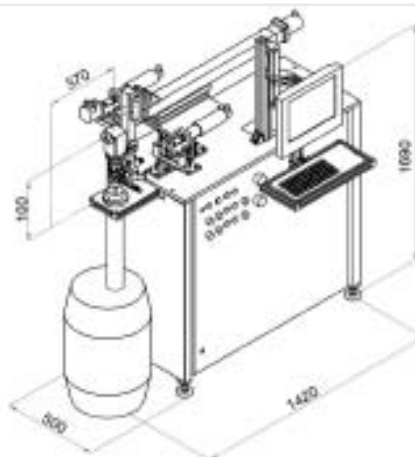

Option

- Material preparation
- Material temperature regulating unit
- Material recirculation unit
- Solvent recirculation unit
- Various process monitoring features
- Product and machine data reporting
- Remote-Lan-Access tools
- Further axis length on request

Contact



BARTEC Dispensing Technology GmbH

Ahornweg 4

D-97990 Weikersheim

Phone: +49 (0) 79 34 / 1 04 - 0

Fax: +49 (0) 79 34 / 1 04 - 3 70

Email: sales@bartec-dispensing.com

www.bartec-dispensing.com