

## Product information

### Dispensing machine B-100



The B-100 is a compact mixing and dispensing machine for processing one and multi-component resins. It is qualified for small series applications and is characterized by its various variation possibilities. Precise time control and special dispensing pumps provide an excellent repeatability.

- Static and dynamic mixing possible
- Adjustable dispensing time
- Potlife monitoring
- Working pressure monitoring

## Application examples of the B-100

### B-100 with hand gun



### B-100 with working table



### B-100 monted on rolls



### B-100 with 3-axis system



## Technical data

Size (w x h x d):	700 x 680 x 640 mm
Weight:	appr. 55 kg (without vessels)
Sliding unit (y-axis):	200 mm manual
Controller:	Time controller BARTEC 2.1
Electrical power supply:	220 V / 16 A / 50 Hz
Air pressure supply:	> 6 bar

## Layout

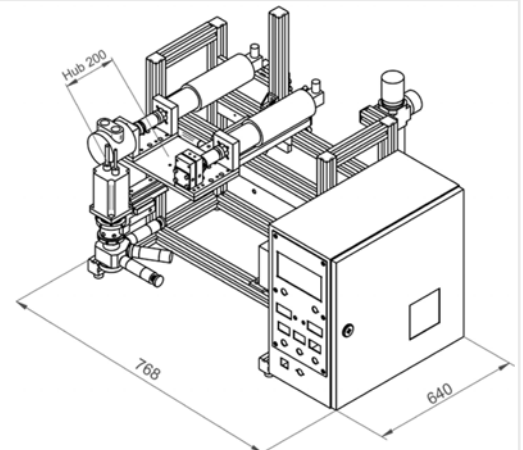

## Options

- Variable material conditioning
- Vessel agitator
- Electrical heating for vessels
- 3-axis table-top robot 200 x 200 x 50 mm (only for 1C und 2C static mixing)

## Contact



### BARTEC Dispensing Technology GmbH

Ahornweg 4  
D-97990 Weikersheim  
Phone: +49 (0) 79 34 / 1 04 - 0  
Fax: +49 (0) 79 34 / 1 04 - 3 70  
Email: [sales@bartec-dispensing.com](mailto:sales@bartec-dispensing.com)  
[www.bartec-dispensing.com](http://www.bartec-dispensing.com)