

Product information

Dispensing machine B-1000



The B-1000 is a flexible mixing and dispensing system for processing one- and multicomponent resins. For process monitoring and for adjusting all dispensing parameters a Siemens S7-200 controller with touch-display is implemented. The machine can be used for integration in external systems or as stand-alone solution.

- Static and dynamic mixing possible
- Automatic potlife and working pressure monitoring
- Visualization via 15"-touch-screen (colored)
- Storage up to 20 different dispensing programs

Application examples of the B-1000

B-1000 mounted on framework



B-1000 mounted on rolls



B-1000 with swivel arm



B-1000 with cross table



Technical data

Size (w x h x d):	900 x 1.700 x 1.050 mm
Weight:	appr. 250 kg (without vessels)
Working area:	Sliding unit in y-direction 200 mm
Controller:	Siemens S7-200
Electrical power supply:	440 V / 16 A / 50 Hz
Air pressure supply:	> 6 bar

Layout

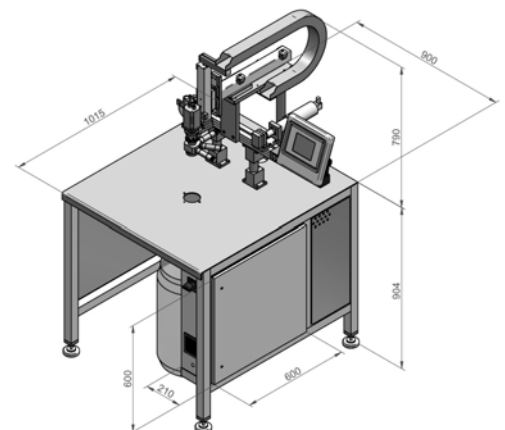

Options

- Variable material conditioning
- Material temperature regulating unit
- Material recirculation
- Solvent recirculation unit
- Filling level monitoring
- Pneumatical y- and z-axis
(y=200 mm, z=100 mm; further length in request)
- Swivel arm

Contact



BARTEC Dispensing Technology GmbH

Ahornweg 4

D-97990 Weikersheim

Phone: +49 (0) 79 34 / 1 04 - 0

Fax: +49 (0) 79 34 / 1 04 - 3 70

Email: sales@bartec-dispensing.com

www.bartec-dispensing.com