

Product information

Dispensing machine B-5600

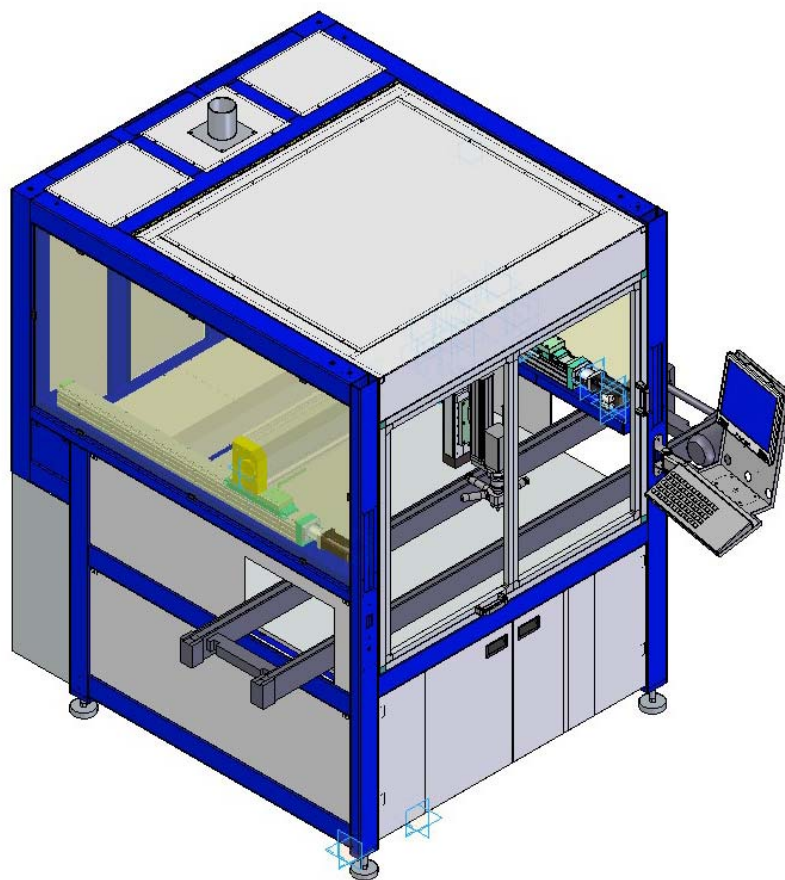

The B-5200 is a mixing and dispensing cell for processing one and multi-component resins in a semi or fully-automated environment. Due to its big and variable working area it is possible to apply a double mixing head system.

This machine is also characterized by its operator-driven controller concept as well as by the flexibility of integrating it into various automation environments.

- Beckhoff-controller, visualization via 17" screen
- 3-axis system with servo-motors
- Possibility to integrated double mixing head system
- Various integration possibilities

Application examples of the B-5600

B-5600 with folding door and conveyor belt

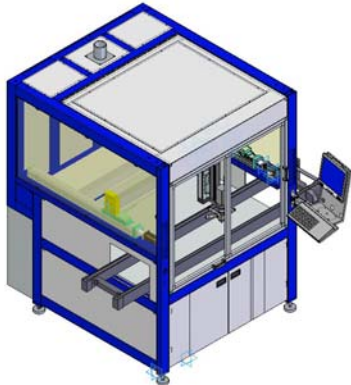

B-5600 with sliding door and rotary table

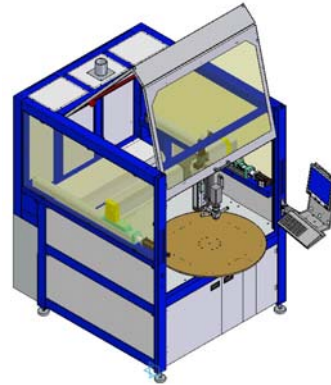

B-5600 with sliding door and sliding unit

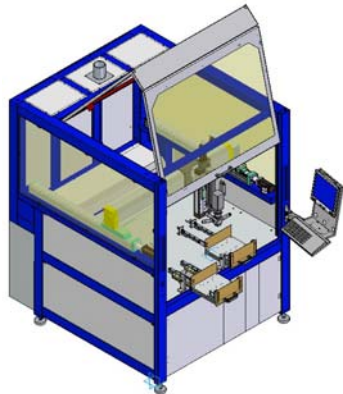

B-5600 with double mixing head

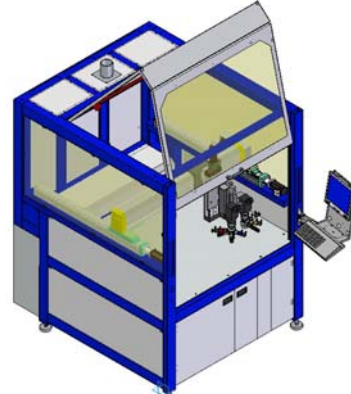

Technical data

Size (w x h x d):	1.590 x 2.200 x 1.800 mm
Weight:	~1.000 kg (without vessels)
Working area (x,y,z):	see working area
Repeatability:	+/-0,052mm per 300 mm stroke
Axis speed:	0,5 m/sec.
Controller:	Beckhoff
Electrical power supply:	440 V / 16 A / 50 Hz
Air pressure supply:	> 6 bar

Working area

	1 dynamic system	2 dynamic systems
Motor y-axis mounted at the front (standard)	x=800 mm y=730 mm z=200 mm	x=500 mm y=730 mm z=200 mm
Motor y-axis mounted at the end	x=800 mm y=730 mm z=200 mm	x=500 mm y=600 mm z=200 mm
Motor y-axis with belt mounted at the end	x=800 mm y=890 mm z=200 mm	x=500 mm y=760 mm z=200 mm

Options

- Material temperature regulating unit
- Material recirculation unit
- Solvent recirculation unit
- Variable material preparations
- Integration of automation processes
- Product and machine data reporting
- Remote-Lan-Access tools
- Various process monitoring features
- Folding door mounted on booth sides

Contact



BARTEC Dispensing Technology GmbH

Ahornweg 4
D-97990 Weikersheim
Phone: +49 (0) 79 34 / 1 04 - 0
Fax: +49 (0) 79 34 / 1 04 - 3 70
Email: sales@bartec-dispensing.com
www.bartec-dispensing.com