

Product information

Dispensing machine B-5200



The B-5200 is a mixing and dispensing cell for processing one and multi-component resins in a semi or fully-automated environment. Due to its 3-axis system, the B-5200 is suitable for almost all kinds of applications. This machine is also characterized by its operator-driven controller concept as well as by the flexibility of integrating it into various automation environments.

- Beckhoff-controller, visualization via 17" screen
- 3-axis system with servo-motors
- Integrated switch cabinet
- Various integration possibilities

Application examples of the B-5200

B-5200 with folding door and conveyor belt

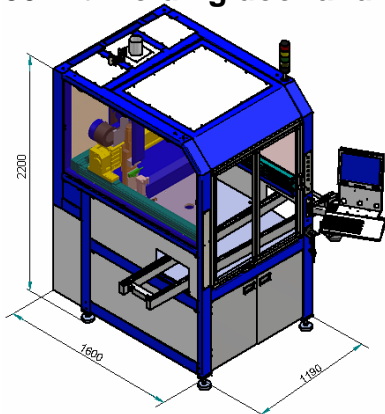

B-5200 with sliding door and rotary table

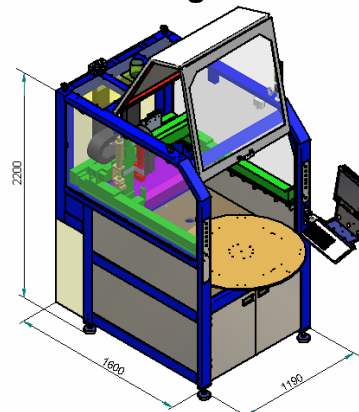

B-5200 with sliding door and sliding unit

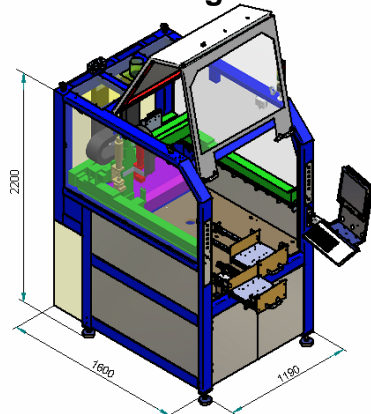

B-5200 with light curtain

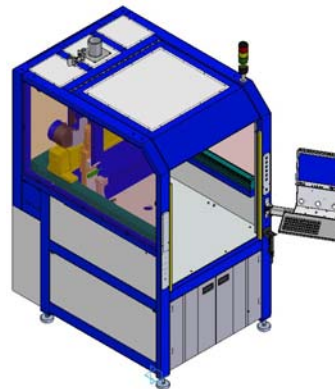

Technical data

Size (w x h x d):	1.190 x 2.130 x 1.600 mm
Weight:	appr. 800 kg (without vessels)
Working area (x,y,z):	max. 400-500 x 700 x 200 mm
Repeatability:	+/-0,052mm per 300 mm stroke
Axis speed:	0,5 m/sec.
Controller:	Beckhoff
Electrical power supply:	440 V / 16 A / 50 Hz
Air pressure supply:	> 6 bar

Layout

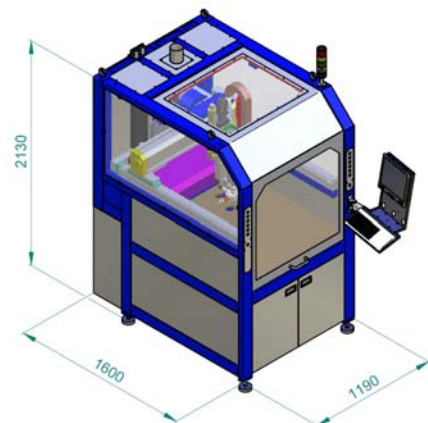

Options

- Material temperature regulating unit
- Material recirculation unit
- Solvent recirculation unit
- Variable material preparations
- Integration of automation processes
- Product and machine data reporting
- Remote-Lan-Access tools
- Various process monitoring features

Contact



BARTEC Dispensing Technology GmbH

Ahornweg 4

D-97990 Weikersheim

Phone: +49 (0) 79 34 / 1 04 - 0

Fax: +49 (0) 79 34 / 1 04 - 3 70

Email: sales@bartec-dispensing.com

www.bartec-dispensing.com