

## B-100 DCD Machine with Static Mixing Technology

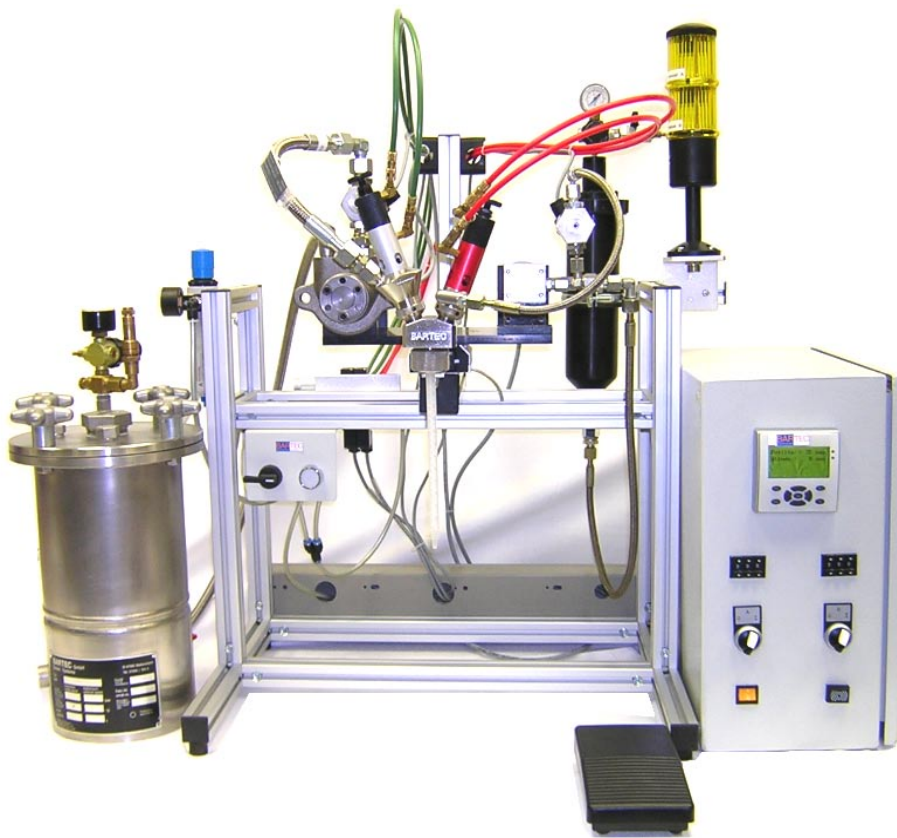

- PLC Controlled system for accuracy and control of all dispensing components
- Pressure sensors will alarm and stop the machine before dispensing incorrect mix ratio or flow rate
- Flexibility with adjustable flow rate and shot size
- Highly accurate volumetric gear pumps and individual dispense valves will deliver an accurate and repeatable production process.

- Individually controlled gear metering pumps for accurate mix ratio
- Variable speed controlled DC motors for pumps to adjust dispensing rates
- Pressure sensors with min/max alarm control, providing on-line process monitoring
- Programmable shot size timer control
- Pot life timer audible alarm
- Mix head moveable on manual slide in horizontal direction, with pneumatic lock
- Foot Pedal switch dispensing actuation
- Material supply from 'Semco' 610 c.c. type cartridge holders or 26.5 Lt. Stainless steel pressure vessels, complete with pressure control and safety relief valves
- Complete with all hoses and pneumatic control system; 110VAC operation
- **Additional options** may be required based on the resin system: Dynamic mixing technology, temperature control, vacuum, vessel agitators, vessel level sensors, recirculation, foam air loading, special pumps and valves for abrasive or high viscosity materials

## B-100 DCD Machine with Static Mixing Technology



### Machine Layout

Side view

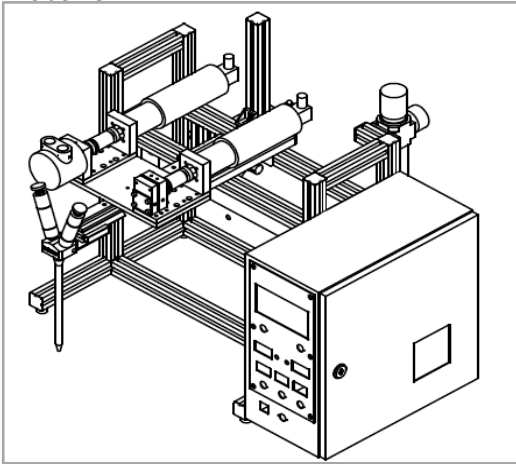

Front view

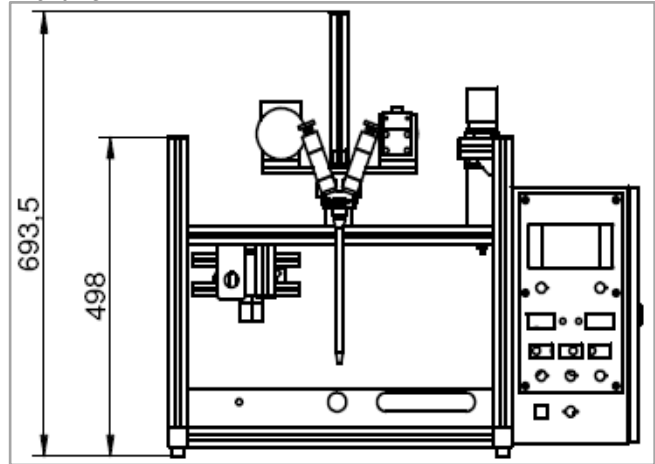

Individually adjustable valves

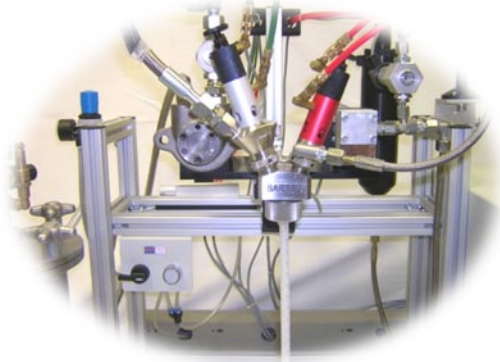

Top view

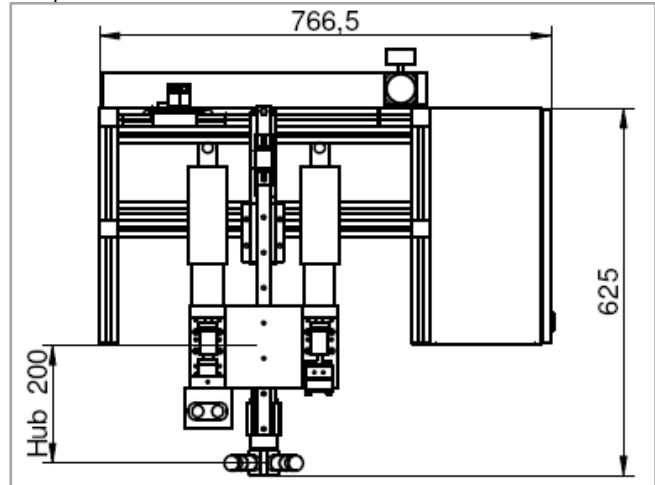

Gear pumps / DC motors / Pressure Sensors

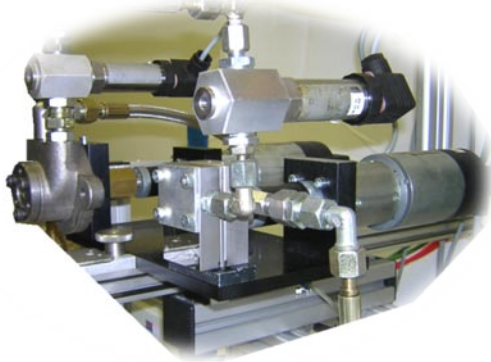

PLC control system



### Contact



BARTEC DISPENSING TECHNOLOGY, Inc.  
5830 S. 129th East Ave.  
Tulsa, OK 74134  
phone: 918-250-6496  
fax: 918-250-6564

[sales@bartec-dt.com](mailto:sales@bartec-dt.com)  
[www.bartec-dt.com](http://www.bartec-dt.com)